

OLSTEFF.COM

Stefano

Gartensessel und Couchtisch | Armchair and coffee table | Fotel i stolik kawowy

Montageanleitung | Assembly instructions | Instrukcja montażu

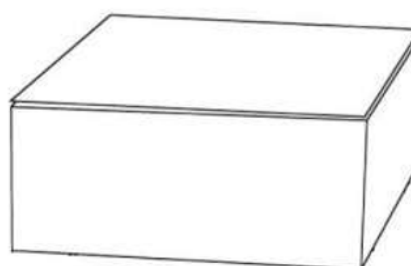
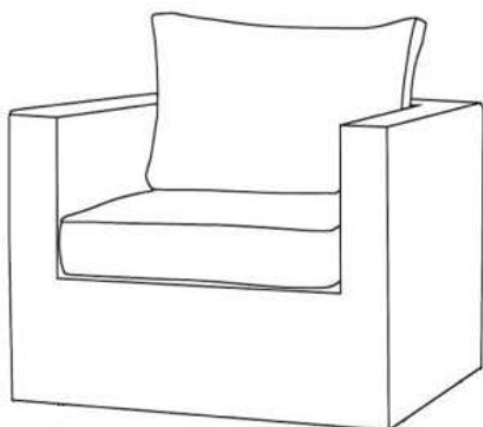

(DE) WICHTIGE INFORMATIONEN

Lesen Sie vor dem Zusammenbau des Produkts die Sicherheitshinweise sorgfältig durch.

Bitte lesen Sie die Montageanleitung und bewahren Sie diese zum späteren Gebrauch auf.

Überprüfen sie bitte, ob das Produkt vollständig ist oder alle Elemente verpackt wurden.

Es können sich lose Teile in der Verpackung und auf Möbelteilen befinden – es sind Rückstände aus dem Produktionsprozess – man sollte sie vor der Zusammenbau entfernen.

Alle Möbelemente sollten auf einer ebenen Fläche zusammengebaut werden.

Um Kratzer zu vermeiden, darf das Produkt auf einem Teppich montiert werden.

Das Set enthält einen Spezialschlüssel, um Schrauben festzuziehen.

Die Schrauben sollten mit dem mitgelieferten Schlüssel festgezogen werden.

Der Schlüssel sollte zum späteren Gebrauch aufbewahrt werden.

Die Möbelemente sollten mit Seife und einem weichen Tuch gereinigt werden.

Die Möbel sind zur Innenbereich bestimmt.

(ENG) IMPORTANT INFORMATION

Before assembling the product, read the safety instructions carefully.

Please read the assembly instructions and keep it for the future reference.

It should be checked whether the product is complete of all the elements have been packed.

Loose components can be found in the package and on furniture parts – residues from the production process – they should be removed before assembly.

All furniture elements should be mounted on a flat surface. To avoid scratches, the product can be mounted on the carpet.

The set includes a special key for tightening the screws.

The screws should be screwed using the included key. The key could be kept for later use.

Furniture element should be cleaned with soap and soft cloth.

The furniture is intended for indoor use.

(PL) WAŻNE INFORMACJE

Przed montażem produktu należy dokładnie zapoznać się ze wskazówkami bezpieczeństwa.

Należy zapoznać się z instrukcją montażu i zachować ją do użytku w przyszłości.

Należy sprawdzić czy produkt jest komplety, czy zapakowane zostały wszystkie elementy.

W paczce oraz na częściach mebli znajdować mogą się luźne elementy – pozostałości po procesie produkcyjnym – przed montażem należy je usunąć.

Wszystkie elementy mebli należy montować na płaskiej powierzchni.

Aby uniknąć zarysowań produkt montowany może być na dywanie / trawniku.

Do kompletu dołączono specjalny klucz służący do dokręcania śrub.











Śruby należy wkręcać za pomocą dołączonego klucza.

Klucz należy zachować do późniejszego użytku.











Elementy mebli należy oczyścić przy pomocy wody z mydłem i miękkiej ściereczki.

Meble przeznaczone są do użytku zewnętrznego.











TEILLISTE DES EINZELSTUHL

A	Rückenlehne		1	G	Nuss	M6*55		12	
B	Sitzfläche		1	H	Inbusschlüssel			1	
C	Linke Armlehne		1	I	Schraubenschlüssel			1	
D	Rechte Armlehne		1	J	Sitzkissen			1	
E	Unterlegscheibe (M6)		12	K	Rückenkissen			1	
F	Schrauben	M6*55		11	L	Schrauben	M6*45		2

PARTS LIST OF SINGLE CHAIR

A	Back Rack		1	G	Nut	M6*55		12
B	Seat Rack		1	H	Allen Key			1
C	Left Arm		1	I	Hex Wrench			1
D	Right Arm		1	J	Seat Cushion			1
E	Washer (M6)		12	K	Back Cushion			1
F	Bolts		11	L	Bolts	M6*45		2

LISTA CZĘŚCI FOTEŁA

A	Oparcie		1	G	Nakrętka	M6*55		12	
B	Siedzisko		1	H	Klucz Imbusowy			1	
C	Lewy podłokietnik		1	I	Klucz płaski			1	
D	Prawy podłokietnik		1	J	Poduszka siedziskowa			1	
E	Podkładka (M6)		12	K	Poduszka oparciowa			1	
F	Śruba	M6*55		11	L	Śruba	M6*45		2

Gebrauchsanleitung | User Manual | Instrukcja montażu

Schritt 1: Montieren Sie die Rücken (A) und das Sitz (B) zusammen mit Innensechskantschrauben (F), Unterlegscheiben (E) und Muttern (G) wie im Bild unten gezeigt.

Step 1: Assemble the back (A) and seat (B) together with hexagon socket screws (F), flat washers (E) and nut (G) as shown below.

Krok 1: Zamontuj oparcie (A) oraz siedzisko (B) za pomocą śruby z gniazdem sześciokątnym (F), płaskiej podkładki (E) i nakrętki (G) jak pokazano na rysunku poniżej.

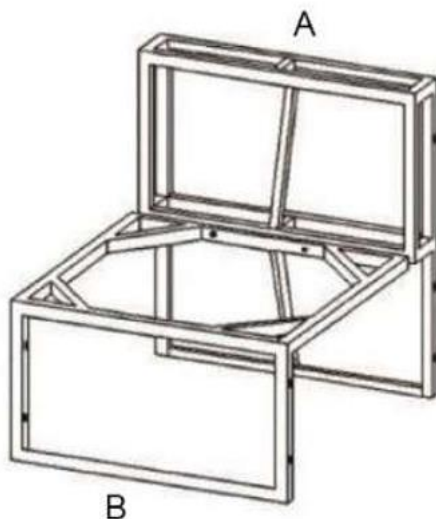

Schritt 2: Befestigen Sie das linke Armlehne (C) an dem Rücken (A) und dem Sitz (B) mit Innensechskantschrauben (F), Unterlegscheiben (E) und Muttern (G) wie im Bild unten gezeigt.

Step 2: Attach the left armrest (C) to the back (A) and the seat (B) with hexagon socket screw (F), nuts (G) and flat washers (E) as shown in picture below.

Krok 2: Dołącz lewy podłokietnik (C) do oparcia (A) i siedziska (B) za pomocą śruby z sześciokątnym gniazdem (F), nakrętki (G) i płaskiej podkładki (E), jak pokazano na rysunku poniżej.

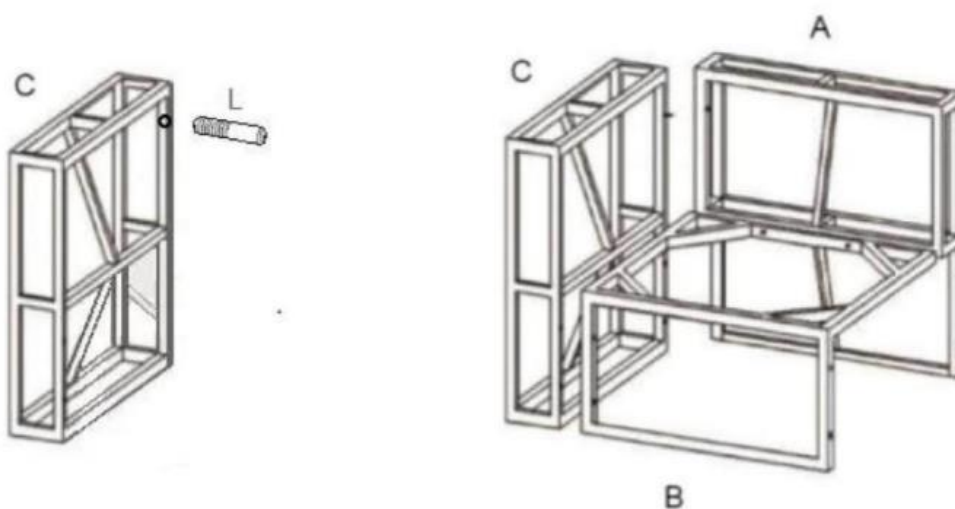

Schritt 3: Befestigen Sie die rechte Armlehne (D) an dem Rücken (A) und dem Sitz (B) mit Innensechskantschrauben (F), Unterlegscheiben (E) und Muttern (G) wie im Bild unten gezeigt.

Step 3: Attach the right armrest (D) to the back (A) and the seat (B) with hexagon socket screw (F), nuts (G) and flat washers (E) as shown in picture below.

Krok 3: Dołącz prawy podłokietnik (D) do oparcia (A) i siedziska (A) za pomocą śruby z sześciokątnym gniazdem (F), nakrętki (G) i płaskiej podkładki (E), jak pokazano na rysunku poniżej.

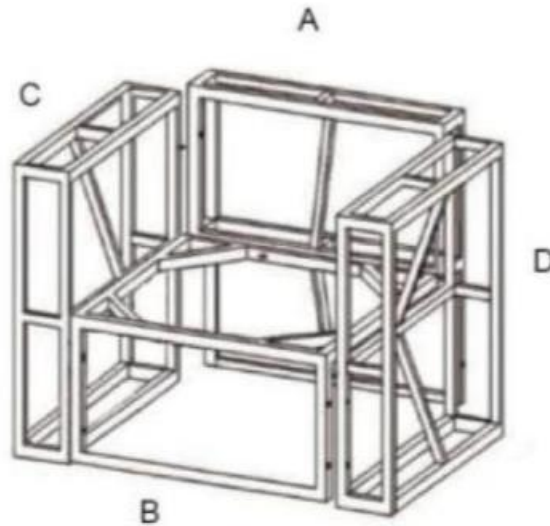





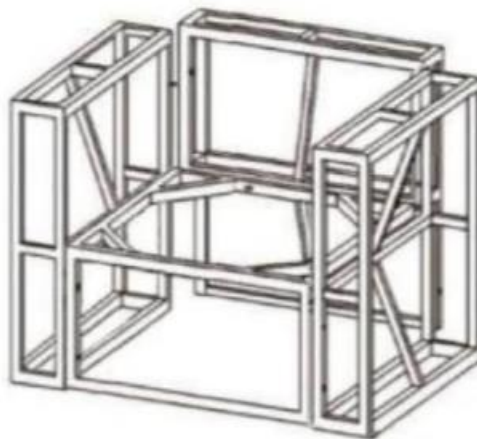

Schritt 4: Verriegeln Sie alle Schrauben fest und beenden Sie die Montage, wie im Bild unten gezeigt.

Step 4: Lock all the bolts tightly and finish the assembly, as shown in picture below



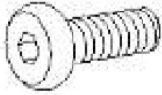



Krok 4: Mocno dokręć wszystkie śruby i dokończ montaż, jak pokazano poniżej





TEILELISTE COUCHTISCH

A	Tischplatte		1	E	Unterlegscheibe	M6*35		12
B	Bein		2	F	Schrauben	M6*35		12
C	Seiten		2	G	Inbusschlüssel	4*4		1
D	Glasplatte		1					

PARTS LIST OF COFFEE TABLE

A	Table Top		1	E	Washer (M6)	M6*35		12
B	Leg		2	F	Bolts	M6*35		12
C	Fixed Rack		2	G	Allen Key	4*4		1
D	Glass top		1					

LISTA CZĘŚCI STOLIKA KAWOWEGO

A	Blat Stołu		1	E	Podkładka (M6)	M6*35		12
B	Noga		2	F	Śruba	M6*35		12
C	Postawa		2	G	Klucz imbusowy	4*4		1
D	Szklany Blat		1					

Gebrauchsanleitung | User Manual | Instrukcja montażu

Schritt 1: Montieren Sie die Tischplatte (A) und das Bein (B) zusammen mit Innensechskantschrauben (F) und Unterlegscheiben (E) wie im Bild unten gezeigt.

Step 1: Assemble the table top (A) and the leg (B) with hexagon sockets crews (F) and flat washers (E) as shown in picture below.

Krok 1: Zamontuj blat stolika (A) z nogami (B) za pomocą śruby z gniazdem sześciokątnym (F), płaskiej

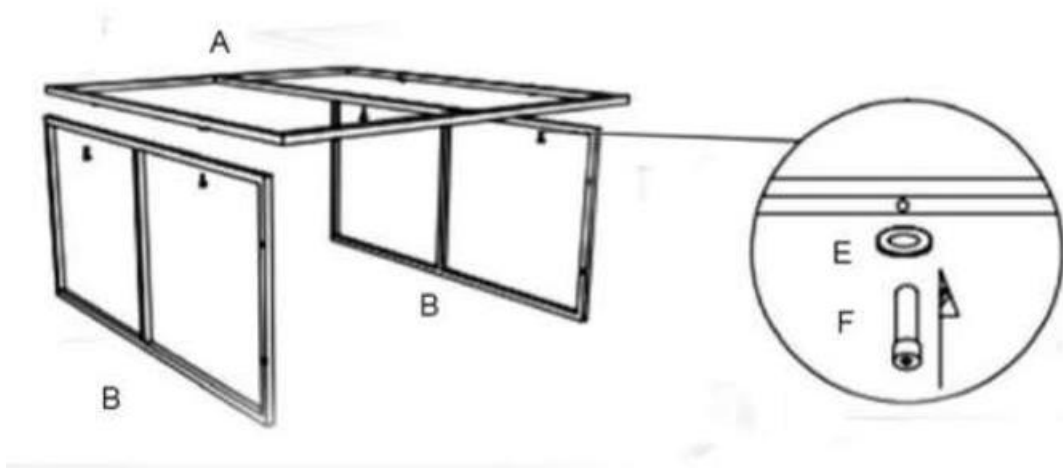

podkładki (E) jak pokazano na rysunku poniżej

Schritt 2: Befestigen Sie das feste Gestell (C) an dem bereits montierten Bein (B) und der Hockerplatte (A) mit Sechskantschrauben (F) und Unterlegscheiben (E) wie im Bild unten gezeigt.

Step 2: Attach the fixed rack (C) to the leg (B) and stool top (A) with hexagon socket screws (F) and flat washers (E) as shown in picture below.

Krok 2: Dołącz boczki stolika (C) do nóg (B) i blatu stolika (A) za pomocą śruby z gniazdem sześciokątnym (F) i płaskiej podkładki (E) jak pokazano na rysunku poniżej.

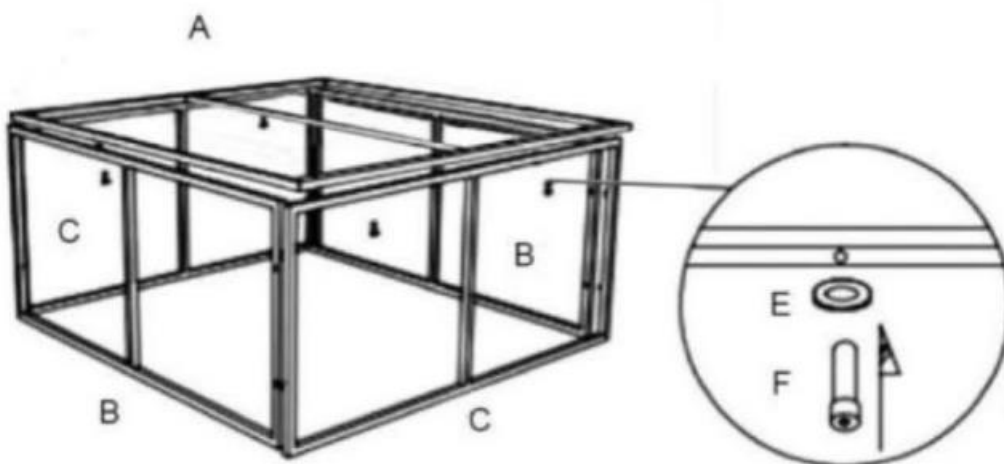

Schritt 3: Verriegeln Sie alle Schrauben fest, setzen Sie dann die Glasplatte(D) auf den Tisch und beenden Sie die Montage, wie im Bild unten gezeigt.

Step3: Lock all the bolts tightly, put the glass on top (D) on the table and finish the assembly as shown in picture below.

Krok 3: Mocno dokręć wszystkie śruby, nałóż szklany blat (D) na stolik i dokończ montaż, jak pokazano poniżej.

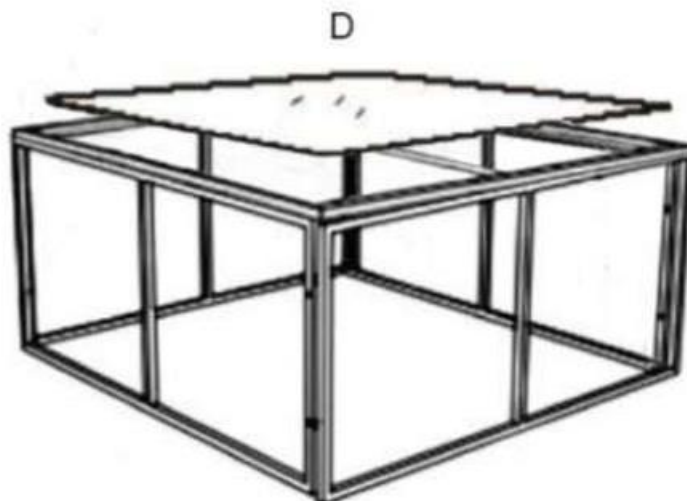

OLSTEFF.COM

Stefano

3-Sitzer-Sofa und Hocker | 3 Seater sofa and Stool | Sofa trzyosobowa i pufa
Montageanleitung | Assembly instructions | Instrukcja montażu

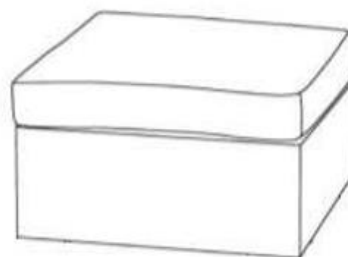
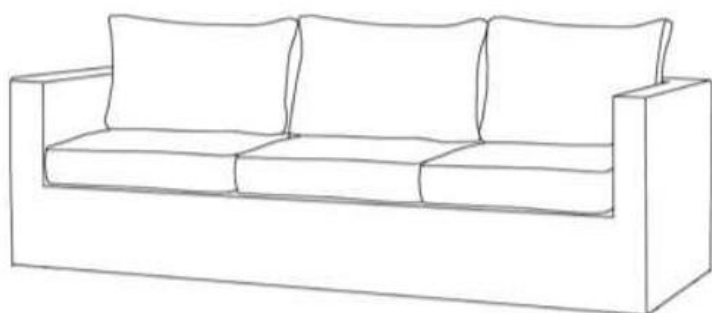

(DE) WICHTIGE INFORMATIONEN

Lesen Sie vor dem Zusammenbau des Produkts die Sicherheitshinweise sorgfältig durch.

Bitte lesen Sie die Montageanleitung und bewahren Sie diese zum späteren Gebrauch auf.

Überprüfen sie bitte, ob das Produkt vollständig ist oder alle Elemente verpackt wurden.

Es können sich lose Teile in der Verpackung und auf Möbelteilen befinden – es sind Rückstände aus dem Produktionsprozess – man sollte sie vor der Zusammenbau entfernen.

Alle Möbelemente sollten auf einer ebenen Fläche zusammgebaut werden.

Um Kratzer zu vermeiden, darf das Produkt auf einem Teppich montiert werden.

Das Set enthält einen Spezialschlüssel, um Schrauben festzuziehen.

Die Schrauben sollten mit dem mitgelieferten Schlüssel festgezogen werden.

Der Schlüssel sollte zum späteren Gebrauch aufbewahrt werden.

Die Möbelemente sollten mit Seife und einem weichen Tuch gereinigt werden.

Die Möbel sind zur Innenbereich bestimmt.

(ENG) IMPORTANT INFORMATION

Before assembling the product, read the safety instructions carefully.

Please read the assembly instructions and keep it for the future reference.

It should be checked whether the product is complete if all the elements have been packed.

Loose components can be found in the package and on furniture parts – residues from the production process – they should be removed before assembly.

All furniture elements should be mounted on a flat surface. To avoid scratches, the product can be mounted on the carpet.

The set includes a special key for tightening the screws.

The screws should be screwed using the included key. The key could be kept for later use.

Furniture element should be cleaned with soap and soft cloth.

The furniture is intended for indoor use.

(PL) WAŻNE INFORMACJE

Przed montażem produktu należy dokładnie zapoznać się ze wskazówkami bezpieczeństwa.

Należy zapoznać się z instrukcją montażu i zachować ją do użytku w przyszłości.

Należy sprawdzić czy produkt jest kompletny, czy zapakowane zostały wszystkie elementy.

W paczce oraz na częściach mebli znajdować mogą się luźne elementy – pozostałości po procesie produkcyjnym – przed montażem należy je usunąć.

Wszystkie elementy mebli należy montować na płaskiej powierzchni.

Aby uniknąć zarysowań produkt montowany może być na dywanie / trawniku.

Do kompletu dołączono specjalny klucz służący do dokręcania śrub.









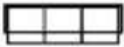

Śruby należy wkręcać za pomocą dołączonego klucza.

Klucz należy zachować do późniejszego użytku.









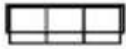

Elementy mebli należy oczyścić przy pomocy wody z mydłem i miękkiej ściereczki.

Meble przeznaczone są do użytku zewnętrznego.









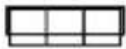

TEILLISTE 3-SITZER-SOFA

A	Rickenlehne		1	G	Nuss		13
B	Sitzflach		1	H	Inbusschlüssel		1
C	Linke Armlehne		1	I	Schraubenschlüssel		1
D	Rechte Armlehne		1	J	Sitzkissen		3
E	Unterlegscheibe		13	K	Rickenkissen		3
F	Schrauben		13	L	Schrauben		2

PARTS LIST OF 3 SEATER SOFA

A	Back Rack		1	G	Nut	M6*50		13	
B	Seat Rack		1	H	Allen Hey	4*4		1	
C	Left Arm		1	I	Wrench	M6		1	
D	Righ Arm		1	J	Seat Cushion			3	
E	Washer (M6)		13	K	Back Cushion			3	
F	Bolts	M6*55		13	L	Bolts	M6*45		2

LISTA CZĘŚCI SOFA TRZYOSOBOWA

A	Oparcie		1	G	Nakrętka	M6*50		13	
B	Siedzisko		1	H	Klucz imbusowy	4*4		1	
C	Lewy podłokietnik		1	I	Klucz płaski	M6		1	
D	Prawy podłokietnik		1	J	Poduszka Siedziskowa			3	
E	Podkładka (M6)		13	K	Poduszka Oparciowa			3	
F	Śruba	M6*55		13	L	Śruba	M6*45		2

Gebrauchsanleitung | User Manual | Instrukcja montażu

Schritt 1: Montieren Sie die Rücken (A) und das Sitz (B) zusammen mit Innensechskantschrauben (F), Unterlegscheiben (E) und Muttern (G) wie im Bild unten gezeigt.

Step 1: Assemble the back (A) and seat (B) together with hexagon socket screws (F), flat washers (E) and nut (G) as shown below.

Krok 1: Zmontuj oparcie (A) z siedziskiem (B) za pomocą śruby z gniazdem sześciokątnym (F), płaskiej podkładki (E) i nakrętki (G) jak pokazano na rysunku poniżej.

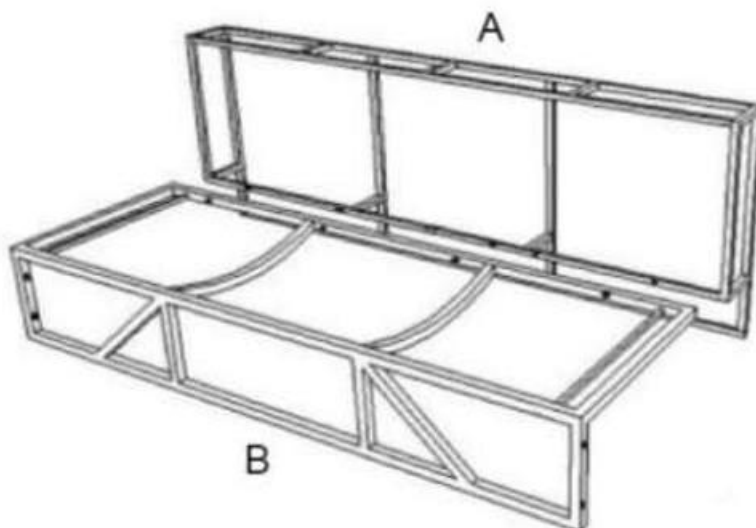

Schritt 2: Befestigen Sie die linke Armelehne (C) an dem Rücken (A) und dem Sitz (B) mit Innensechskantschrauben (F), Unterlegscheiben (E) und Muttern (G) wie im Bild unten gezeigt.

Step 2: Attach the left armrest (C) to the back (A) and the seat (B) with hexagon socket screw (F), nuts (G) and flat washers (E) as shown in picture below.

Krok 2: Dołącz lewy podłokietnik (C) do oparcia (A) i siedziska (B) za pomocą śruby z sześciokątnym gniazdem (F), nakrętki (G) i płaskiej podkładki (E), jak pokazano na rysunku poniżej.

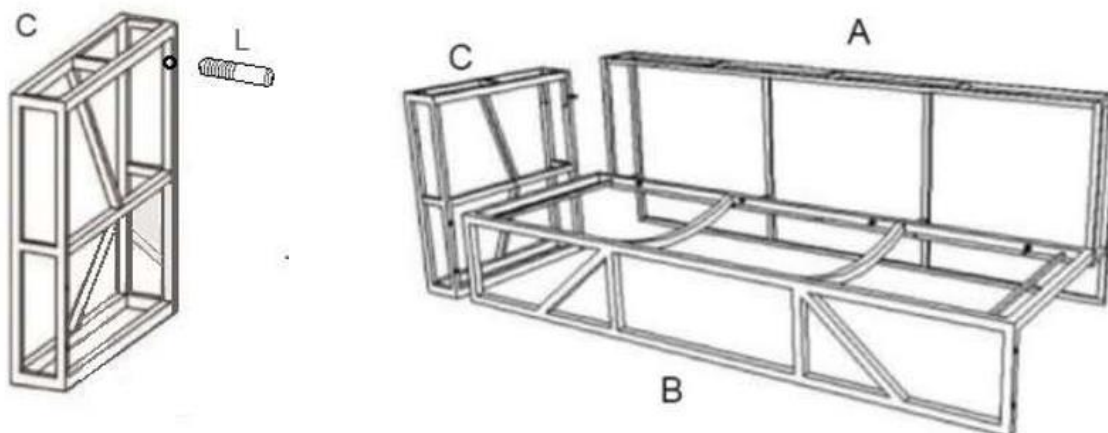

Schritt 3: Befestige Sie die rechte Armlehne (D) an den Rücken (A) und dem Sitz (B) mit Innensechskantschrauben (F), Muttern (G) und Unterlegscheiben (E) wie im Bild unten gezeigt.

Step 3: Attach the right armrest (D) to the back (A) and the seat (B) with hexagon socket screw (F), nuts (G) and flat washers (E) as shown in picture below.

Krok 3: Dołącz prawy podłokietnik (D) do oparcia (A) i siedziska (B) za pomocą śruby z sześciokątnym gniazdem (F), nakrętki (G) i płaskiej podkładki (E), jak pokazano na rysunku poniżej.

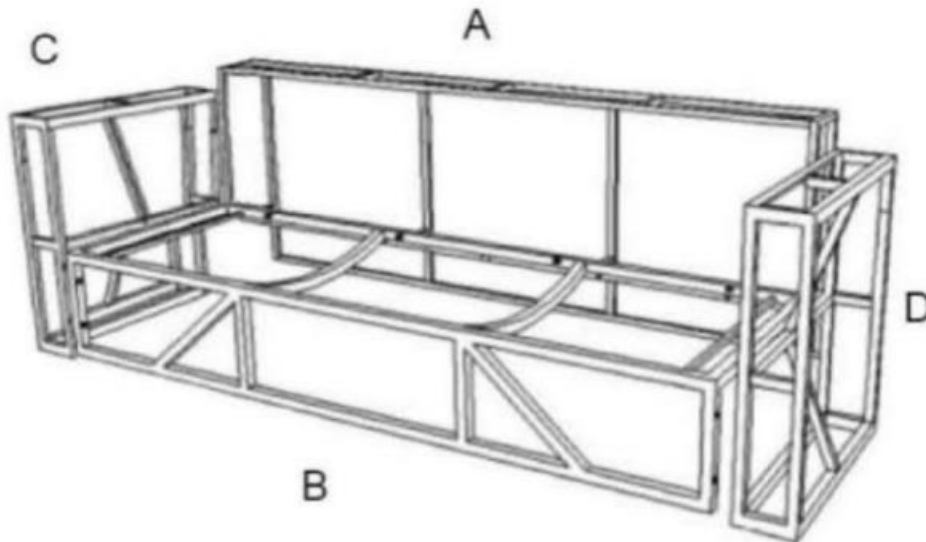





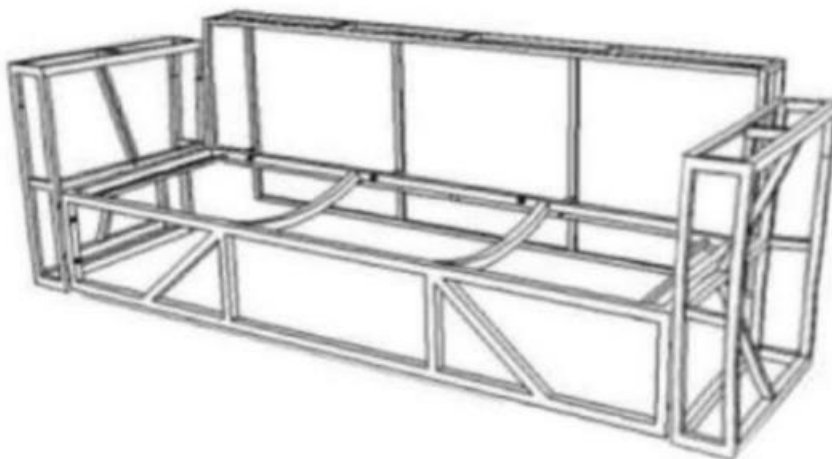

Schritt 4: Verriegeln Sie alle Schrauben fest und beenden Sie die Montage, wie im Bild unten gezeigt.

Step 4: Lock all the bolts tightly and finish the assembly, as shown in picture below.







Krok 4: Mocno dokręć wszystkie śruby i dokończ montaż, jak pokazano poniżej.



TEILELISTE COUCHTISCH

A	Tischplatte		1	E	Schrauben	M6*35		12
B	Bein		2	F	Inbusschlüssel	4*4		1
C	Seiten		2	G	Sitzkissen			1
D	Unterlegscheibe (M6)		12					

PARTS LIST OF STOOL

A	Stool Top		1	E	Bolts	M6*35		12
B	Leg		2	F	Allen Key	4*4		1
C	Fixed Rack		2	G	Seat Cushion			1
D	Washer (M6)		12					

LISTA CZĘŚCI PUFY

A	Góra pufy		1	E	Śruba	M6*35		12
B	Noga		1	F	Klucz imbusowy	4*4		1
C	Bok		1	G	Poduszka siedziskowa			1
D	Podkładka (M6)		12					

Gebrauchsanleitung | User Manual | Instrukcja montażu

Schritt 1: Montieren Sie die Hockerplatte (A) und das Bein (B) zusammen mit Innensechskantschrauben (E) und Unterlegscheiben (D) wie im Bild unten gezeigt.

Step 1: Assemble the top (A) and the leg (B) with hexagon socket screws (E) and flat washers (D) as shown below.

Krok 1: Zamontuj górę pufy (A) z nogami (B) za pomocą śruby z gniazdem sześciokątnym (E) i płaskiej podkładki (D) jak pokazano na rysunku poniżej.

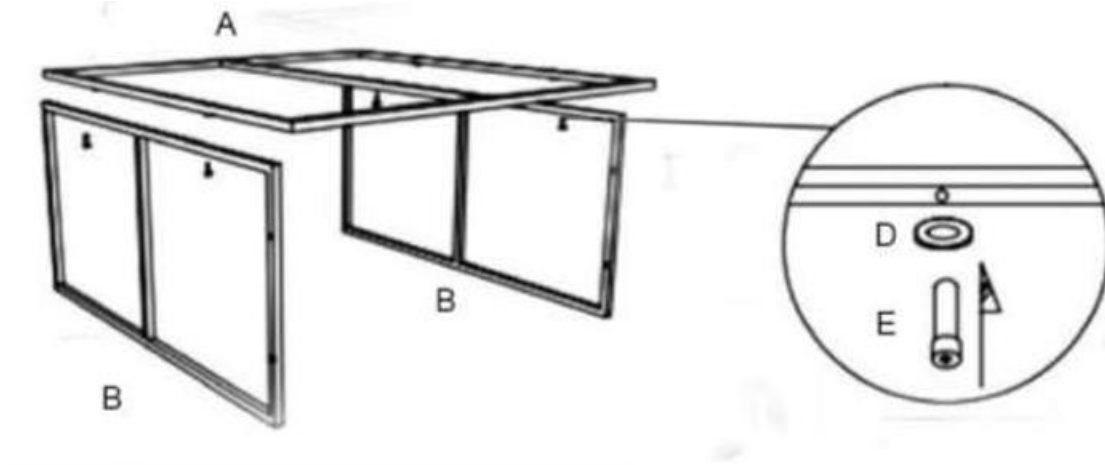

Schritt 2: Befestigen Sie das feste Gestell (C) an dem bereits montieren Bein (B) und der Hockerplatte (A) mit Sechskantschrauben (E) und Unterlegscheiben (D) wie im Bild unten gezeigt.

Step 2: Attach the fixed rack (C) to the leg (B) and stool top (A) with hexagon socket screw (E) and flat washer (D) as shown in the picture below.

Krok 2: Dołącz boczki (C) do nóg (B) i góry pufy (A) za pomocą śruby z sześciokątnym gniazdem (E) i płaskiej podkładki (D), jak pokazano na rysunku poniżej.

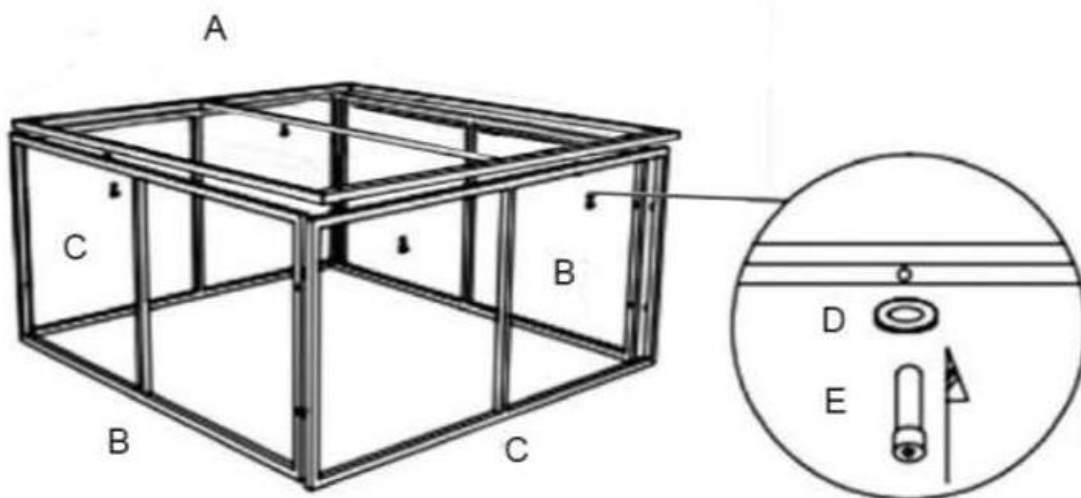

Schritt 3: Verriegeln Sie alle Schrauben fest und beenden Sie die Montage, wie im Bild unten gezeigt.

Step 3: Lock all the bolts tightly and finish the assembly, as shown in picture below.

Krok 3: Mocno dokręć wszystkie śruby i dokończ montaż, jak pokazano poniżej.

